

Date

City / Location

Project name

Type

QTY

Aluminium rail poles c/w two-piece base covers.

DESCRIPTION

The rail system allows adjustable height for multiple accessories. It eliminates primitive straps that can damage the surfaces and restores the aesthetic appearance of a decorative urban pole. Using standard hardware, this unique versatile system has been design to install accessories quickly and securely.

CONSTRUCTION

- Cast aluminium: 356.1
- Extruded aluminium: 6061-T6 alloy.
- Ø6" [152mm] extruded aluminium tube.
- Wall thickness: 0.2" [5.1mm]
- Access door: 15.75" [400mm] × 4.75" [121mm] sealed cast aluminium access door with anti theft screws.
- Anchor base plate welded inside and outside the perimeter of the tube.
- Two-piece cast aluminium base cover (optional) held captive by the anchor base plate.
- Aluminium ground lug.
- Stainless steel hardware.
- All metallic parts are pretreated using an environmentally friendly organic phosphating technology (PLAFORIZATION) before a polyester powder coating is electrostatically applied.
- Four (4) galvanized steel 1-8×30" anchor bolts with eight (8) washers and nuts (9.95 lb [4.52 kg]).

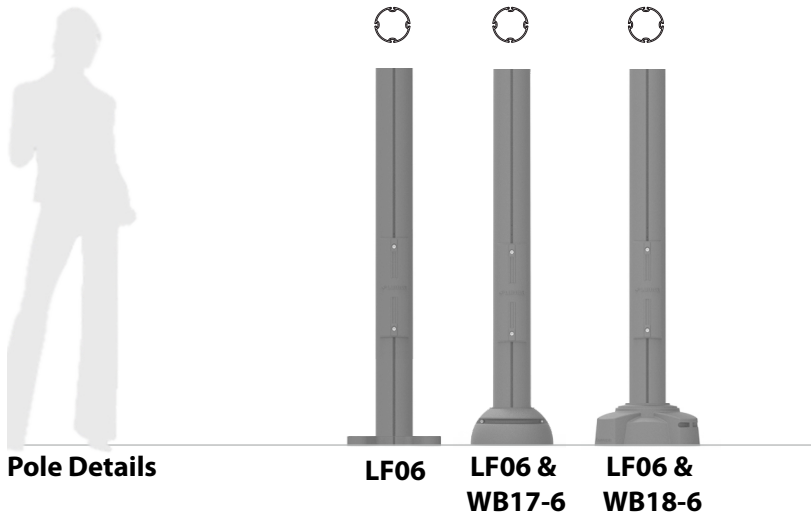

Pole Details

LF06

LF06 &
WB17-6

LF06 &
WB18-6

Max height: 26' [7.9m]

Cast aluminium access door mechanically fixed to the pole.

Two-piece decorative cast aluminium base cover mechanically secured with stainless steel screws c/w retaining lip sliding underneath the base plate.

Recommended anchor bolts projection: 4" [102mm] maximum

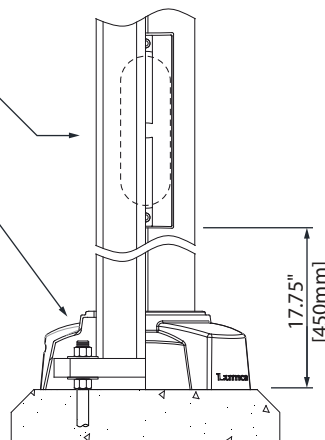

WB17-6 Base cover

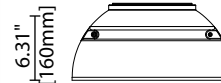
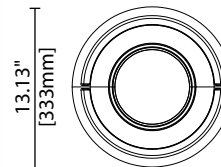

WB18-6 Base cover

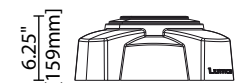
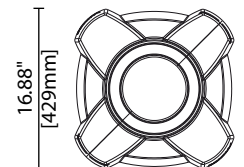

Ordering example: LF06-20 WB18-6 BK

Pole

Height



Base Cover

Color

Options



Anchor Bolts



Bolt circle Ø
11" [280mm] to 15.5" [394mm]
(Ø1" Bolts only)



WB17-6 only: Bolt circle Ø
9" [229mm] to 10" [254mm]
(Ø3/4" Bolts only, max. 20' [6.10m])

- Supplied by LUMCA
- Supplied by others
- Existing



Lumca reserves the right to modify the elements on this technical data sheet without prior notice.

Click on for more information

LF06 round aluminium pole

catalog #	HEIGHT		WALL		WEIGHT		MAX EPA (ft ²)* as per AASHTO LRFDLTS-1										
	ft	m	in	mm	lbs	kg	Wind (mph)										
							70	80	90	100	110	120	130	140	150	160	170
LF06-12	12	3.66	0.2	5.1	67	30	48.56	40.81	40.81	40.81	37.05	31.27	26.72	23.08	20.12	17.64	15.52
LF06-14	14	4.27	0.2	5.1	78	36	34.68	29.03	29.03	29.03	29.03	26.00	22.18	19.15	16.68	14.60	12.80
LF06-16	16	4.88	0.2	5.1	90	41	25.22	20.95	20.95	20.95	20.95	20.95	18.44	15.90	13.84	12.08	10.54
LF06-18	18	5.49	0.2	5.1	101	46	18.45	15.16	15.16	15.16	15.16	15.16	15.16	13.16	11.44	9.95	8.62
LF06-20	20	6.10	0.2	5.1	112	51	13.66	11.01	11.01	11.01	11.01	11.01	11.01	10.97	9.51	8.23	7.08
LF06-22	22	6.71	0.2	5.1	123	56	10.04	7.93	7.93	7.93	7.93	7.93	7.93	7.93	7.92	6.81	5.80
LF06-24	24	7.32	0.2	5.1	134	61	7.32	5.55	5.55	5.55	5.55	5.55	5.55	5.55	5.55	5.55	4.71
LF06-26	26	7.92	0.2	5.1	146	66	5.13	3.65	3.65	3.65	3.65	3.65	3.65	3.65	3.65	3.65	3.65

CHART VALUES REPRESENTING MINIMUM BETWEEN SERVICEABILITY & ULTIMATE

MAX EPA computed at top of pole (HEIGHT) w/r to ground level at base.

*** Including a gust effect factor of 1.14 as per LRFDLTS-1 art. 3.8.6**

NOTE: This EPA chart is for reference only. The maximum EPA may vary depending on the positioning of special equipment required. Please consult factory for evaluation.

Lumca reserves the right to modify the elements on this technical data sheet without prior notice.

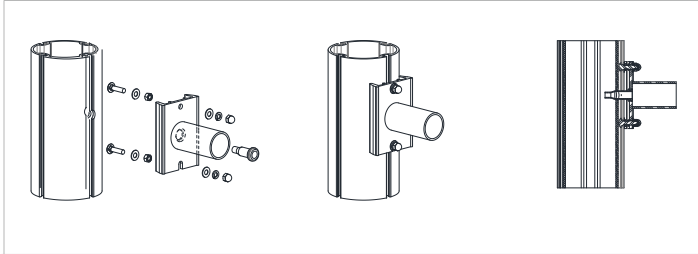

RAIL SYSTEM DETAILS

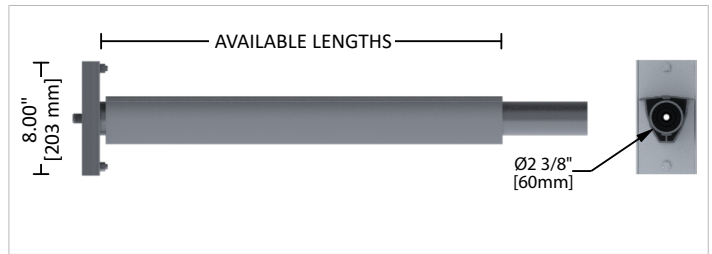

LF-CF550B

Mid pole configuration
Available lengths: 0.3M, 0.5M, 0.72M

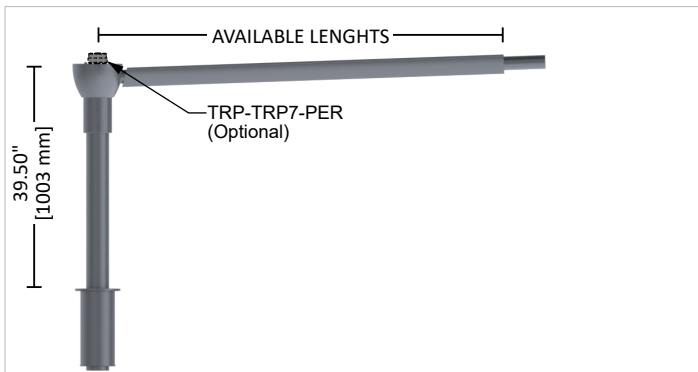

M1-CF550A

Single Configuration
Available lengths: 0.72M, 1.5M, 1.8M, 2.3M

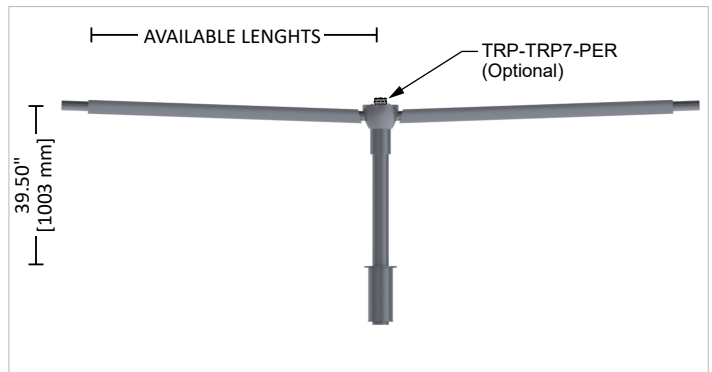

M2-CF550A

Twin Configuration
Available lengths: 0.72M, 1.5M, 1.8M, 2.3M

See website for other available mounting arms

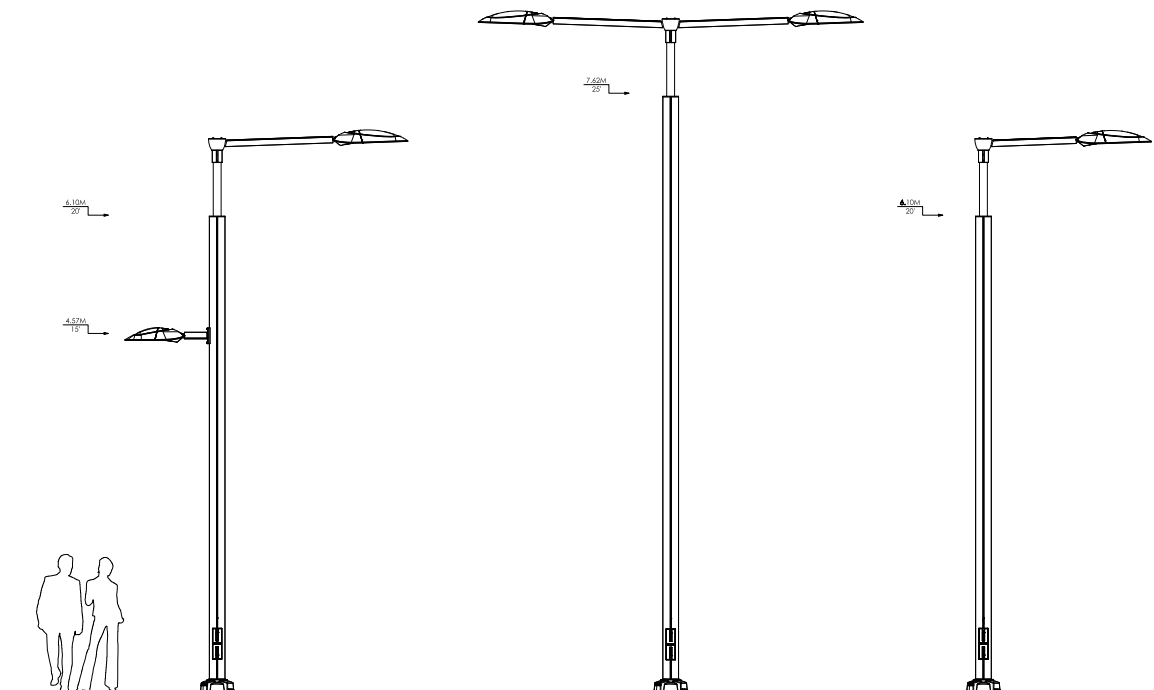

Lumca reserves the right to modify the elements on this technical data sheet without prior notice.

- Opalin white acrylic lens
- Ø4" [102mm]

MK6-4x12R MK6-4x20R	MK6-4x12G MK6-4x20G	MK6-4x12B MK6-4x20B	MK6-4x12W MK6-4x20W	MK6-4x12RGBW MK6-4x20RGBW
--------------------------------------	--------------------------------------	--------------------------------------	--------------------------------------	--

LED accent marker

LF-BR
Bike rack

LF-BH
Basket hanger

LF-LRS
Banner holder

LF-SH
Street sign holder

HEIGHT ADJUSTABLE ATTACHMENT FOR ACCESSORIES

LF-B1
Single bench

LF-B2
Double bench

Bench configuration
For LF-B1 & LF-B2 benches

GFR6-ICA
Duplex c/w aluminum in-use cover

GFR6-ICP
Duplex c/w clear plastic in-use cover

GFR6-ICR
Duplex c/w retractable in-use cover

PWL
Pedestrian LED access door

160° beam
800 lumens

LF6-FIL
Catenary wires holder

Lumca reserves the right to modify the elements on this technical data sheet without prior notice.